



## MODEL 5650 SPEEDPANEL WITH EXPANSION GAP SPACERS

SPEEDPANEL WITH EXPANSION GAP SPACERS

Drawing 5650-5

INSTALLATION INSTRUCTIONS

FRL - / 120 / -

- 1. INITIAL DAMPER TEST** Before installing remove the fusible link and check that the damper opens and closes firmly, replace the fusible link and bend the strap into it's original position. For 5000 series dampers the link must be engaged by clamping vice grips around the shaft and turning anti-clockwise until the link clicks into place then turn clockwise and the blades should open. To dis-engage link use a long screw driver to move the link away from the mechanism which will spring forward, keep hands clear.
2. Advise builder of damper location and direction of airflow.
3. The penetration should be lined with Speedpanel trim angle which the damper, complete with metal expansion gap spacers, should fit into snug (fill any small gaps ie: 4mm and under with intumescent mastic). All dampers are clearly marked with "**TOP**" and "**AIRFLOW DIRECTION**" labels which must be adhered to, remove angles/channels from one side of the damper slide into the penetration, replace angles/channels and insert intumescent mastic between angle/channel and wall.
4. Now that the damper is securely fixed and sealed within the Speedpanel wall repeat **POINT #1 INITIAL DAMPER TEST**.
5. Connect ductwork to damper ensuring break away requirements are maintained.

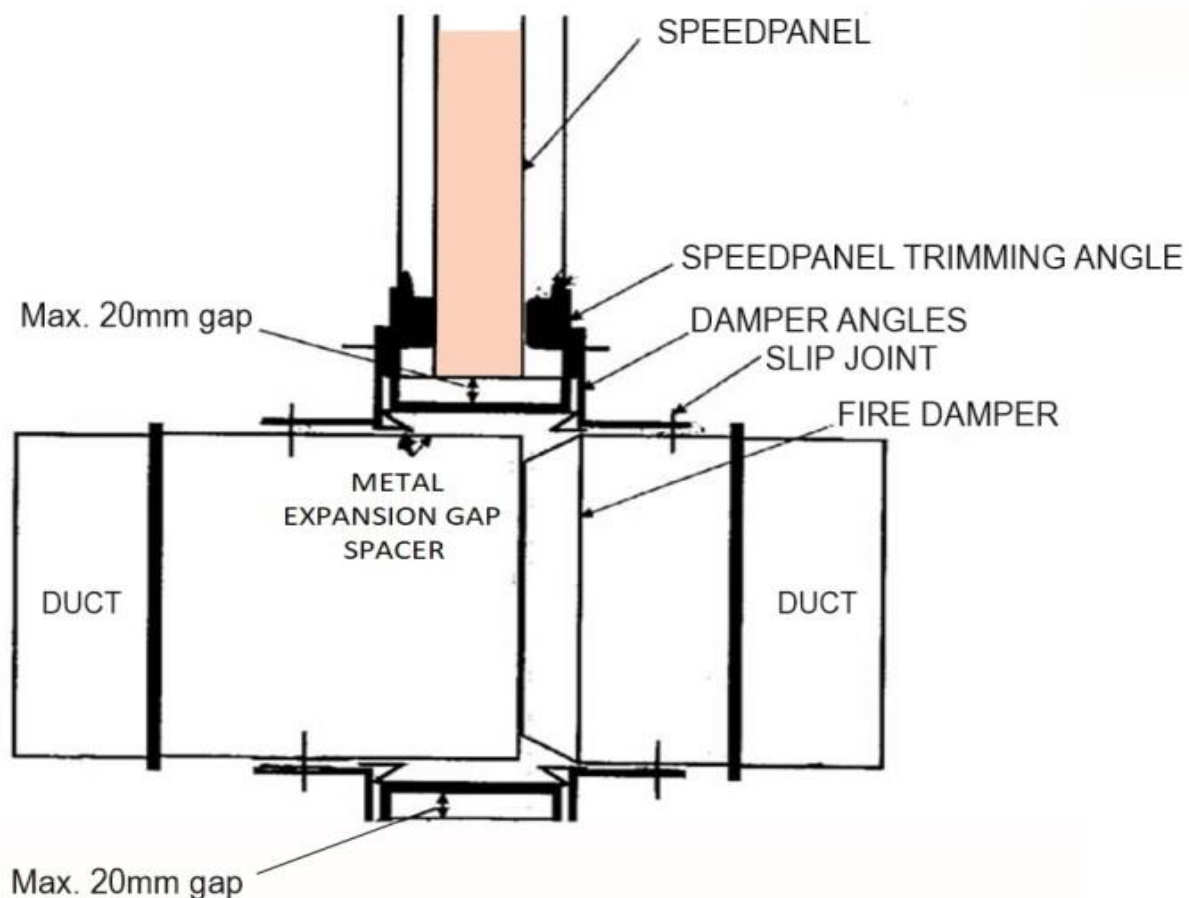

### MAINTENANCE INSTRUCTIONS

All fire dampers shall be accessible and maintained in accordance with AS1851.6

Your local representatives details can be located at [www.bullockmfg.com.au](http://www.bullockmfg.com.au)

