

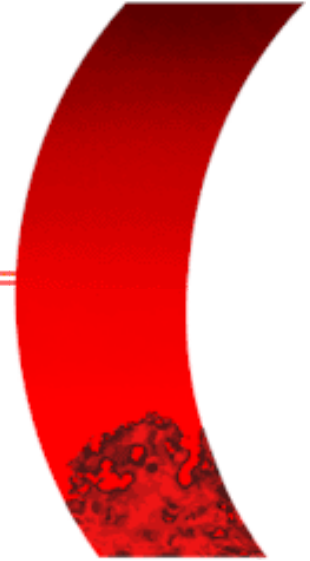

BULLOCK MFG Pty Ltd.

Model 9900 Intumescent Fire Damper



Product Description

The Bullock Model 9900 intumescent Fire Dampers are designed to impede the spread of fire and combustible materials to other compartments through air handling systems. The evenly spaced intumescent strips expand on heat to form a solid barrier against flame, smoke and hot gases. Complying with AS1682.1-1990 and AS/NZS1668.1-1998, the model 9900 is certified for a 4 hour rating in a masonry wall or concrete slab, a 2 hour rating in a steel stud plasterboard wall or a 3x16mm firestop plasterboard ventshaft partition.

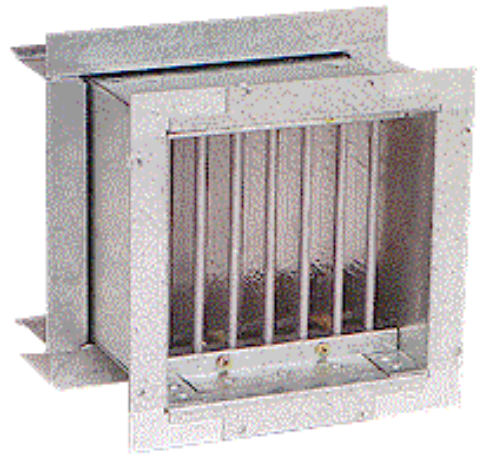
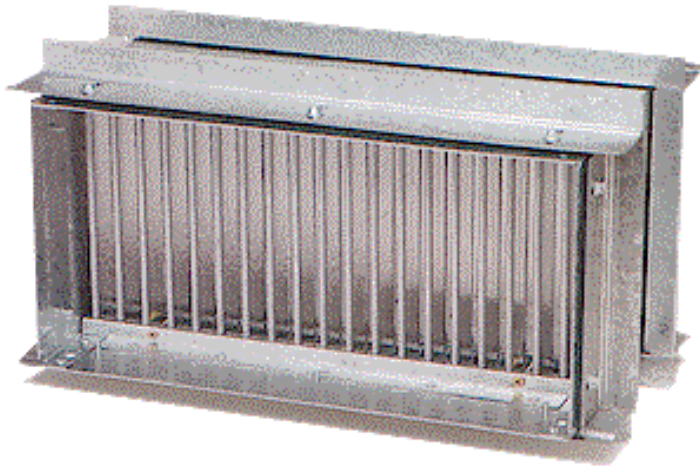

Model 9900 Intumescent Fire Damper



Product Features

- CSIRO AS1682.1-1990 assessment -#FCO-1798.
- Complies with AS/NZS1668.1-1998, AS1682.1-1990.
- Fire Resistant Level. (FRL)
 - a) Masonry Wall - 4 hours
 - b) Concrete Slab - 4 hours
 - c) Steel Stud plasterboard wall - 2 hours
 - d) 3x16mm Plasterboard partition - 2 hours
- Lightweight construction without welding ensures the integrity of damper's galvanised coating.
- Recessed angle or optional TDF/TDC flanges supplied for easy duct connection.
- Optional fraction set 10mm metal expansion gap seals are available at time of ordering, to enable damper to be built into brickwork without a lintel support ensuring compliance with AS1682.2-1990 section 5.2.
- Closure rate within 120 second criteria of AS/NZS1668.1-1998.
- Each strip contains a core of intumescent material, sheathed in aluminium foil for ease of maintenance to AS1851.6-1997.
- Duct to Duct (D) and Duct to Grille (GS) configurations in sizes 100mmx100mm up to 400mmx 250mm available at short notice.

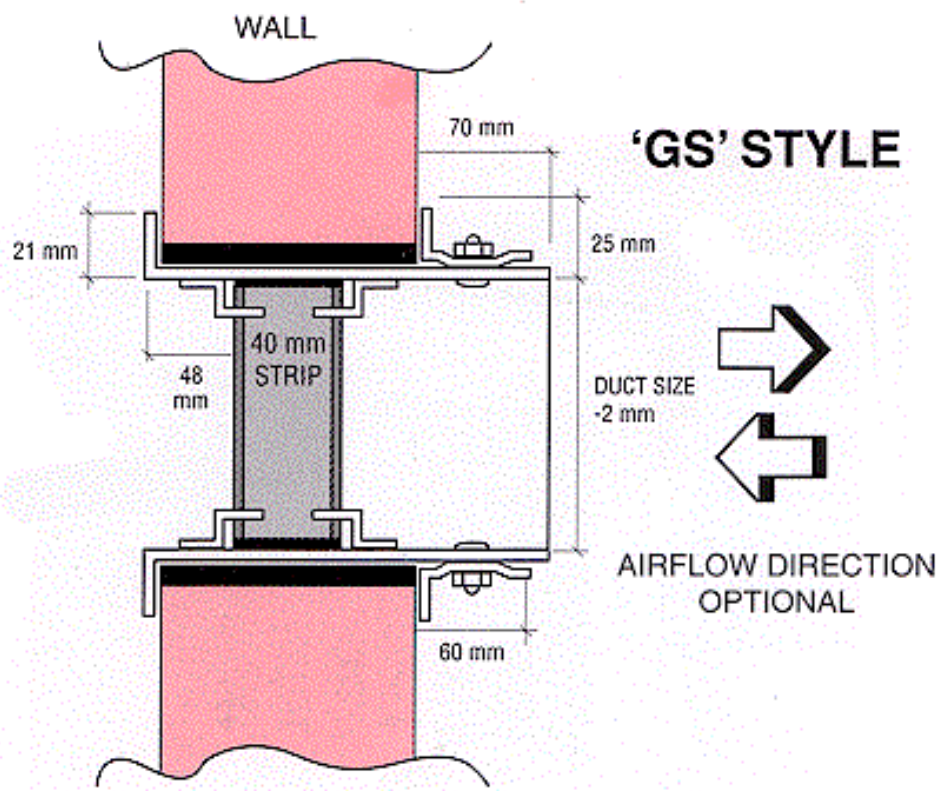
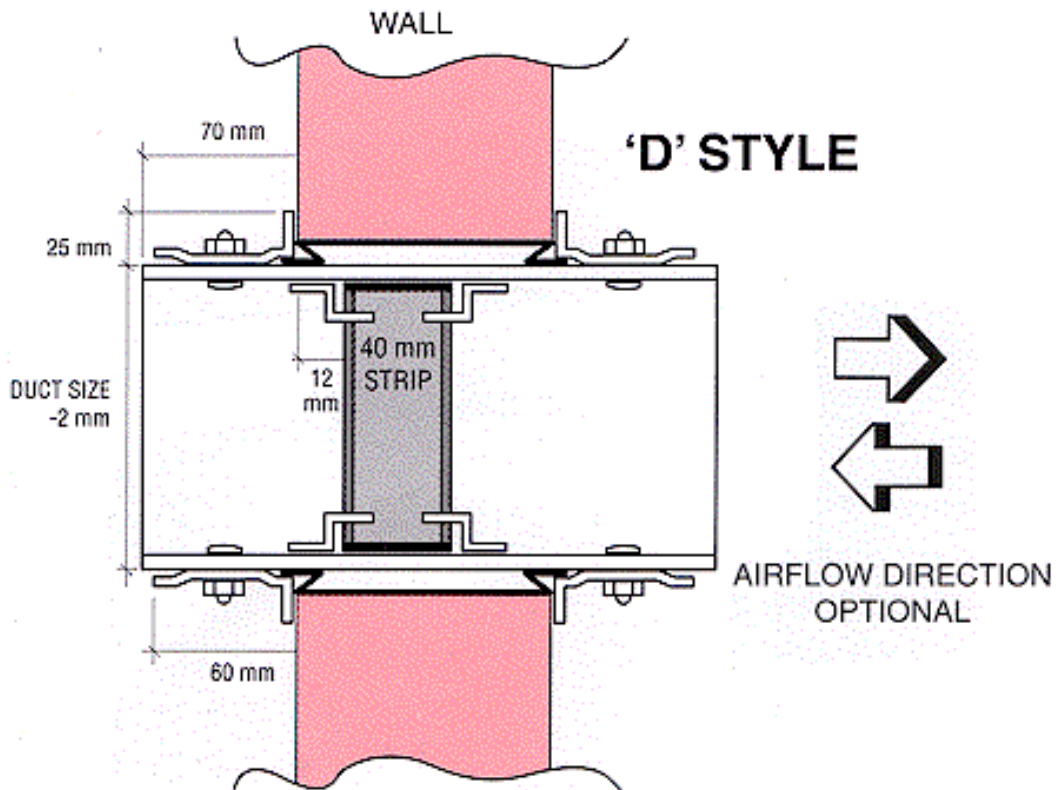

Installation

Compliance with installation instructions is critical. Refer to separate wall/slab type installation instructions to suit your requirements. Please refer to installation Page.

Maintenance

This model requires little maintenance once installed. Refer to AS1851.6-1997 for detailed servicing procedures.

Specifications are subject to change without notice.

BULLOCK MFG P/L ~ 22 Pike St. Rydalmere. NSW 2116 Ph: (02)9684 1311 Fax: (02)9684 2250

BULLOCK VIC P/L ~ 54 Tarnard Dr. Braeside. VIC 3195 Ph: (03)9587 5522 Fax: (03)9587 6622

BULLOCK WA P/L ~ 34 Industry St. Malaga. WA 6062 Ph: (08)9248 1633 Fax: (08)9248 1733

BULLOCK INDUSTRIES P/L ~ 26 Quindus St, Wacol. QLD 4076 Ph: (07) 3271 2088 Fax: (07)3271 1892

BULLOCK SA P/L ~ U1 Commercial Crt. Dry Creek. SA 5094 Ph: (08) 8349 7088 Fax: (08)8349 7066

email: bullmfg@bigpond.net.au

Copyright © 2004 Bullock Manufacturing Pty Limited. All Rights Reserved.